



INSTRUCTION & SAFETY MANUAL

5 A SIL 3 Relay Output Module for NE Load,
with full diagnostic and Modbus, DIN-Rail,
Power Bus and Termination Board, Model D5293S



Characteristics

General Description: The D5293S is a relay module suitable for the switching of safety related circuits, up to SIL 3 level according to IEC 61508:2010 Ed.2, for high risk industries. It provides isolation between input and output contacts. A wide compatibility towards different DCS/PLC is guaranteed: driving line pulse testing, executed by DCS/PLC, is permitted by a dedicated internal circuit, to prevent relay and LED flickering. D5293S provides 1+1 SPST contact for normally energized load. SIL 3 Safety Function for NE load (de-energized in fail safe state) is available at Terminal Blocks 13-14. When the driving signal is high (24 Vdc), the relay is energized (normal state), SIL 3 contacts at terminals 13-15 and 14-16 are closed, the load is energized. The safety function is met when the driving signal is low (0 Vdc), the relay is de-energized (fail safe state), SIL 3 contacts at terminals 13-15 and 14-16 are open, the load is de-energized. Load is isolated from supply on both polarities: +/AC, -/AC.

Load and Line Diagnostic: Line and load short/open circuit detection is provided. Load RMS voltage and current are measured by the module. Load voltage and current can automatically be acquired from field. User configurable limits set the minimum and maximum values of supply voltage (DC or AC) and load current. The fault in the field is directly mirrored to the PLC DO: few systems may exceptionally require an external resistor at terminals 7 and 8. All diagnostic conditions, that detect a fault on line and load, open the fault relay contacts and are also available from a RS485 Modbus output to identify any specific fault. Diagnostic functions with fault relay NO contacts and RS485 Modbus output are SIL 2 rated according to IEC 61511. Mounting on standard DIN-Rail, with or without Power Bus, or on customized Termination Boards, in Safe Area / Non Hazardous Location or in Zone 2 / Class I, Division 2 or Class I, Zone 2.

Functional Safety Management Certification:

G.M. International is certified by TUV to conform to IEC61508:2010 part 1 clauses 5-6 for safety related systems up to and included SIL3.



Technical Data

Supply: 24 Vdc nom (21.6 to 27.6 Vdc) reverse polarity protected, ripple within voltage limits ≤ 5 Vpp, 2 A time lag fuse internally protected.

Current consumption @ 24 V: 40 mA typical, with channel energized and no fault.

Power dissipation: 1 W typical.

Isolation (Test Voltage): Output/Input 2.5 KV; Output/Supply 2.5 KV;

Output/Fault Outputs 2.5 KV; Output/RS485 Modbus 2.5 KV;

Input/Supply 500 V; Input/Fault Output 1 500 V; Input/Fault Output 2 2.5 KV;

Input/RS485 Modbus 500 V; Supply/Fault Output 1 500 V;

Supply/Fault Output 2 2.5 KV; Supply/RS485 Modbus 500 V.

Input: 24 Vdc nom (21.6 to 27.6 Vdc) reverse polarity protected, ripple within voltage limits ≤ 5 Vpp.

Current consumption @ 24 V: 40 mA (with mirror and no fault).

Power dissipation @ 24 V: 1 W (with mirror and no fault).

Output: voltage free 1 + 1 SPST relay contact at terminals 13-15 and 14-16, opens when relay is de-energized (fail safe state), close in energized condition.

Contact material: Ag Alloy (Cd free), gold plated.

Contact rating: 5 A 250 Vac 1250 VA, 5 A 250 Vdc 140 W (resistive load). Min. switching current 1 mA.

Contact inrush current: 6 A at 24 Vdc, 250 Vac.

Mechanical / Electrical life: $5 * 10^6 / 3 * 10^4$ operation, typical.

Operate / Release time: 8 / 4 ms typical.

Bounce time NO / NC contact: 3 / 8 ms, typical.

Frequency response: 10 Hz maximum.

Fault detection: load and line short/open circuit monitoring

Short output detection: programmable load current (5 mA to 5 A typical).

Open output detection: programmable load current (5 mA to 5 A typical).

Fault signaling: voltage free NE 1 + 1 SPST relay contacts (closed in normal operation), output de-energized (with contacts open) in fault condition. Fault contacts can be reversed via software.

Fault 1 output rating: 500 mA 30 Vac 15 VA, 500 mA 50 Vdc 25 W (resistive load).

Fault 2 output rating: 3 A 250 Vac 750 VA, 3 A 125 Vdc 120 W (resistive load).

Response time: 3/4 sec typical.

Modbus Output: measure data, load and line diagnostic monitoring.

Modbus RTU protocol up to 115.2 Kbit/s with RS-485 connection on terminal blocks and Power Bus connector.

Terminating impedance: 100 Ω software selectable.

Transmission speed: 4.8, 9.6, 19.2, 38.4, 57.6, 115.2 Kbit/s.

Transmission cable length: ≤ 1200 m up to 93.75 Kbit/s, ≤ 1000 m up to 115.2 Kbit/s.

Compatibility:

CE mark compliant, conforms to Directive: 2014/34/EU ATEX, 2014/30/EU EMC, 2014/35/EU LVD, 2011/65/EU RoHS.

Environmental conditions:

Operating: temperature limits - 40 to + 60 °C, relative humidity 95 %, up to 55 °C.

Storage: temperature limits - 45 to + 80 °C.

Safety Description:



ATEX: II 3G Ex nA nC IIC T4 Gc

IECEX / INMETRO / NEPSI: Ex nA nC IIC T4 Gc

FM: NI / I / 2 / ABCD / T4, I / 2 / AEx nA nC / IIC / T4

FMC: NI / I / 2 / ABCD / T4, I / 2 / Ex nA nC / IIC / T4

EAC-EX: 2ExnAnCIICT4 X.

UKR TR n. 898: 2ExnAnCIICT4 X.

non-sparking electrical equipment. -40 °C \leq Ta \leq 70 °C.

Approvals:

BVS 10 ATEX E 114 conforms to EN60079-0, EN60079-15.

IECEX BVS 10.0072 X conforms to IEC60079-0, IEC60079-15.

INMETRO DNV 13.0109 X conforms to ABNT NBR IEC60079-0, ABNT NBR IEC60079-15.

UL & C-UL E477485 conforms to ANSI/UL508

FM 3046304 and FMC 3046304C conforms to Class 3600, 3611, 3810, ANSI/ISA-60079-0, ANSI/ISA-60079-15, C22.2 No.142, C22.2 No.213, C22.2 No. 60079-0, C22.2 No. 60079-15.

C-IT.ME92.B.00206 conforms to GOST 30852.0, 30852.14.

CLJ 16.0036 X conforms to DCTV 7113, DCTV IEC 60079-15.

GYJ14.1406X conforms to GB3836.1, GB3836.8.

TUV Certificate No. C-IS-236198-04, SIL 3 conforms to IEC61508:2010 Ed.2.

TUV Certificate No. C-IS-236198-09, SIL 3 Functional Safety Certificate conforms to IEC61508:2010 Ed.2, for Management of Functional Safety.

SIL 2 conforms to IEC 61511 for Line and Load Diagnostic Functionalities (Pending).

DNV Type Approval Certificate No.A-13625 and KR No.MIL20769-EL002 Certificates for maritime applications .

Patent No. 0001406495 , released on 28/02/2014, valid for 20 years.

Mounting: T35 DIN-Rail according to EN50022, with or without Power Bus or on customized Termination Board.

Weight: about 230 g.

Connection: by polarized plug-in disconnect screw terminal blocks to accommodate terminations up to 2.5 mm².

Location: installation in Safe Area/Non Hazardous Locations or Zone 2, Group IIC T4 or Class I, Division 2, Group A,B,C,D, T4 or Class I, Zone 2, Group IIC, T4.

Protection class: IP 20.

Dimensions: Width 22.5 mm, Depth 123 mm, Height 120 mm.

DC Load breaking capacity:

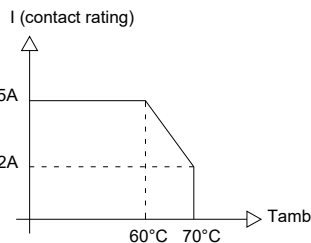
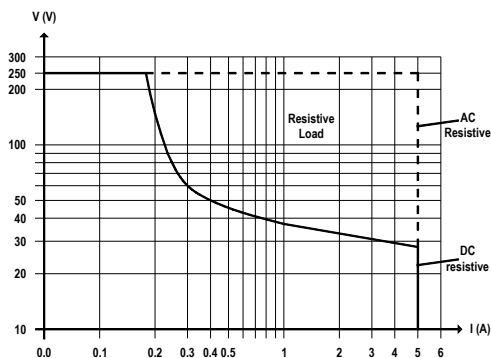

Programming

The module is fully programmable to set the operation parameters from PC by the GM Pocket Portable Adapter PPC5092 via USB serial line and SWC5090 Configurator software. Measured values and diagnostic alarms can be read on both serial configuration or Modbus output line.

Available diagnostic functions:

Load status	Load voltage	Load open circuit	Load short circuit	Load to earth leakage	Internal coil short
OFF	PF				
ON	PF	PF	PF		

F = available function

PF = available function with programmable thresholds

Ordering information

Model: D5293S

Power Bus and DIN-Rail accessories:

Connector JDFT050

Terminal block male MOR017

Cover and fix MCHP196

Terminal block female MOR022

Operating parameters are programmable from PC by the GM Pocket Portable Adapter PPC5092 via USB serial line and SWC5090 Configurator software.

Front Panel and Features

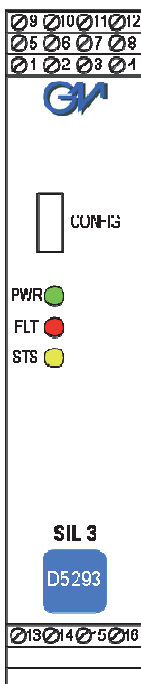

- SIL 3 according to IEC 61508:2010 Ed. 2 for Tproof = 13 / 20 yrs ($\leq 10\%$ / $> 10\%$ of total SIF) for NE Load, PFDavg (1 year) 7.55 E-06, SFF 98.70%
- SIL 2 according to IEC 61511 for Tproof = 2 / 5 yrs ($\leq 10\%$ / $> 10\%$ of total SIF) for diagnostic with fault relay NO contact, with PFDavg (1 yr) 3.83 E-04, SFF 68.92 %
- SIL 2 according to IEC 61511 for Tproof = 5 / 10 yrs ($\leq 10\%$ / $> 10\%$ of total SIF) for diagnostic with RS485 Modbus out, with PFDavg(1 yr) E-04, SFF 73.64%
- Systematic capability SIL 3.
- Installation in Zone 2 / Division 2.
- Compatible with DCS/PLC pulse testing.
- Line and Load short/open circuit detection.
- The fault in the field is directly mirrored to the PLC DO.
- RMS voltage and load current measurement.
- Automatic acquisition of voltage and current values.
- 5 A SIL 3 contacts for NE load.
- 6 A inrush current at 24 Vdc / 250 Vac.
- Input/Output/Supply isolation.
- EMC Compatibility to EN61000-6-2, EN61000-6-4, EN61326-1, EN61326-3-1 for safety system.
- ATEX, IECEx, UL & C-UL, FM & FM-C, INMETRO, EAC-EX, UKR TR n. 898, NEPSI, TÜV Certifications.
- TÜV Functional Safety Certification.
- Type Approval Certificate DNV and KR for maritime applications.
- Simplified installation using standard DIN-Rail and plug-in terminal blocks, with or without Power Bus, or customized Termination Boards.

Terminal block connections

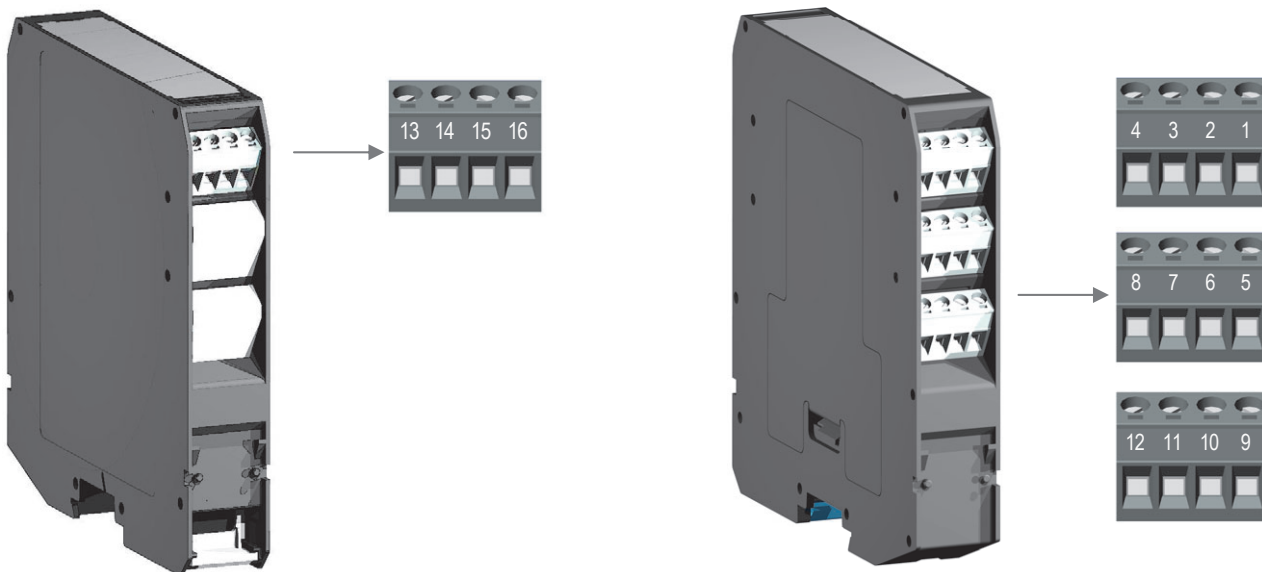

SAFE AREA

- 13** (SIL 3) + Output Normally Energized Load
- 14** (SIL 3) - Output Normally Energized Load
- 15** + Load Power DC/AC
- 16** - Load Power DC/AC

- 1** + Input
- 2** - Input
- 3** Fault Output 1 (30 V, 500 mA)
- 4** Fault Output 1 (30 V, 500 mA)
- 5** A- Modbus Input/Output RS485
- 6** B+ Modbus Input/Output RS485
- 7** (Optional External Resistor)
- 8** (Optional External Resistor)
- 9** + Power Supply 24 Vdc
- 10** - Power Supply 24 Vdc
- 11** Fault Output 2 (250 V, 3 A)
- 12** Fault Output 2 (250 V, 3 A)

Function Diagram

SAFE AREA, ZONE 2 GROUP IIC T4,
NON HAZARDOUS LOCATIONS, CLASS I, DIVISION 2,
GROUPS A, B, C, D T-Code T4, CLASS I, ZONE 2, GROUP IIC T4

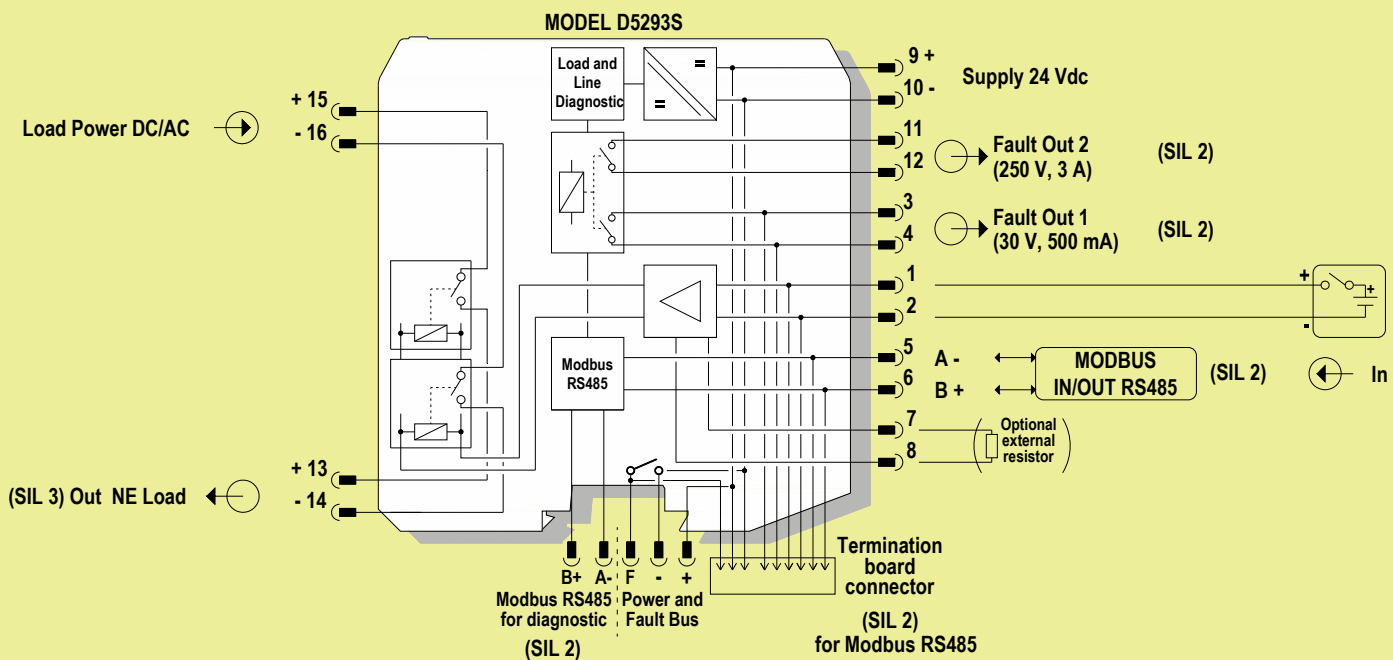

All relay contacts are shown
in de-energized position

**To prevent relay contacts from damaging, connect an external protection (fuse or similar),
chosen according to the relay breaking capacity diagram.**

Application for D5293S - SIL 3 Load Normally Energized Condition (NE)

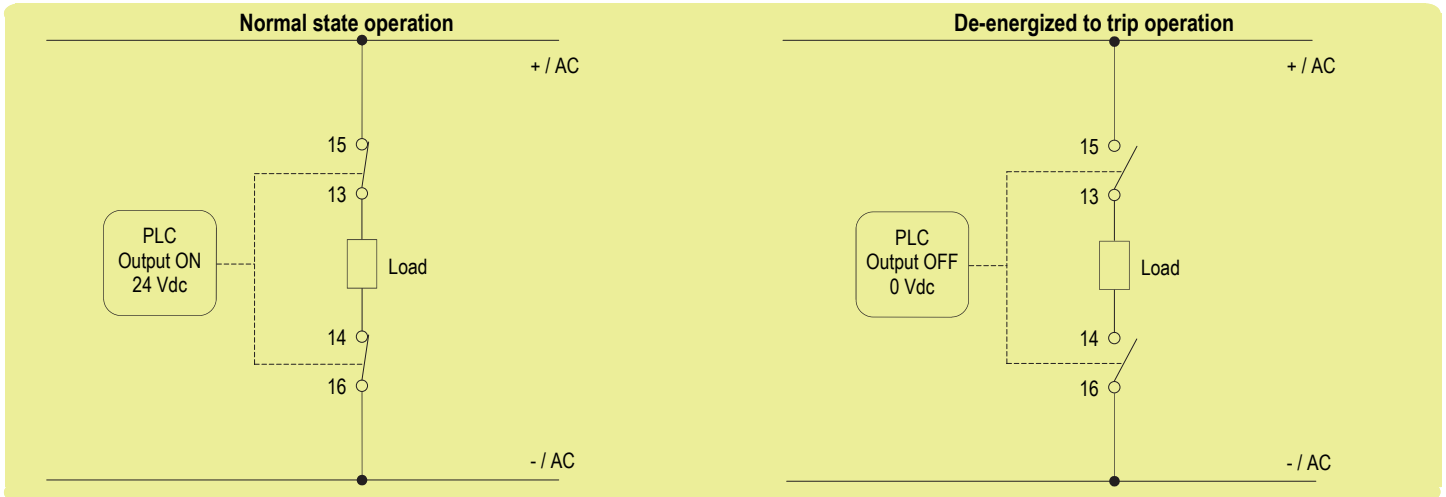

Description:

Input Signal from PLC/DCS is normally High (24 Vdc) and is applied to pins 1-2 in order to Normally Energize (NE) the internal relays. Input Signal from PLC/DCS is Low (0 Vdc) during “de-energized to trip” operation, in order to de-energize the internal relays. The Load is Normally Energized (NE), therefore its safe state is to be de-energized. Disconnection of the NE Load is done on both supply lines. The following table describes the status (open or closed) of each output contact when the input signal is High or Low.

Operation	Input Signal Pins 1-2	Pins 15 - 13	Pins 16 - 14	NE Load (SIL3) Pins 13 - 14
Normal	High (24 Vdc)	Closed	Closed	Energized
Trip	Low (0 Vdc)	Open	Open	De-Energized

Safety Function and Failure behavior:

D5293S is considered to be operating in Low Demand mode, as a Type A module, having Hardware Fault Tolerance (HFT) = 0. In this Functional Safety application, the normal state operation of relay module is energized, with NE (Normally Energized) load. In case of alarm or request from process, the relay module is de-energized (safe state), de-energizing the load.

The failure behaviour of the relay module is described by the following definitions:

- fail-Safe State: it is defined as the output load being de-energized;
- fail Safe: this failure causes the system to go to the defined fail-safe state without a process demand;
- fail Dangerous: failure mode that does not respond to a demand from the process (i.e. being unable to go to the defined fail-safe state), so that the output load remains energized.
- fail “No effect”: failure mode of a component that plays a part in implementing the safety function but is neither a safe failure nor a dangerous failure; When calculating the SFF this failure mode is not taken into account.
- fail “Not part”: failure mode of a component which is not part of the safety function but part of the circuit diagram and is listed for completeness; When calculating the SFF this failure mode is not taken into account.

Failure rate date: taken from Siemens Standard SN29500.

Failure rate table:

Failure category	Failure rates (FIT)
λ_{dd} = Total Dangerous Detected failures	0.00
λ_{du} = Total Dangerous Undetected failures	1.72
λ_{sd} = Total Safe Detected failures	0.00
λ_{su} = Total Safe Undetected failures	173.66
$\lambda_{tot\ safe}$ = Total Failure Rate (Safety Function) = $\lambda_{dd} + \lambda_{du} + \lambda_{sd} + \lambda_{su}$	175.38
MTBF (safety function, single channel) = $(1 / \lambda_{tot\ safe}) + MTTR$ (8 hours)	650 years
$\lambda_{no\ effect}$ = “No effect” failures	132.82
$\lambda_{not\ part}$ = “Not Part” failures	554.69
$\lambda_{tot\ device}$ = Total Failure Rate (Device) = $\lambda_{tot\ safe} + \lambda_{no\ effect} + \lambda_{not\ part}$	862.89
MTBF (device, single channel) = $(1 / \lambda_{tot\ device}) + MTTR$ (8 hours)	132 years

Failure rates table according to IEC 61508:

λ_{sd}	λ_{su}	λ_{dd}	λ_{du}	SFF
0.00 FIT	173.66 FIT	0.00 FIT	1.72 FIT	99.02%

PFDavg vs T[Proof] table (assuming Proof Test coverage of 99%), with determination of SIL supposing module contributes 10% of entire safety function:

T[Proof] = 1 year	T[Proof] = 13 years	T[Proof] = 20 years
PFDavg = 7.55 E-06 - Valid for SIL 3	PFDavg = 9.81 E-05 - Valid for SIL 3	PFDavg = 1.51 E-04 - Valid for SIL 2

PFDavg vs T[Proof] table (assuming Proof Test coverage of 99%), with determination of SIL supposing module contributes 20% of entire safety function:

T[Proof] = 20 years
PFDavg = 1.51 E-04 - Valid for SIL 3

Systematic capability SIL 3.

Testing procedure at T-proof

The proof test shall be performed to reveal dangerous faults which are undetected by diagnostic. This means that it is necessary to specify how dangerous undetected faults, which have been noted during the FMEDA, can be revealed during proof test.

Before of specific Proof test, execute the following **general proof test**: connect the load supply lines to terminal blocks "15" (for +/AC) and "16" (-/AC) and the NE output load to terminal blocks "13" (as the positive terminal) and "14" (as the negative terminal); finally, connect the DCS/PLC signal to input channel terminal blocks "1" (as the positive terminal) and "2" (as the negative terminal). Then, verify the input to output functionality: the output NE load is Normally Energized by supplying the input channel, while shutdown of the input channel de-energizes (safe state) the load. The channel functionality must be verified for a min to max input voltage change (21.6 to 27.6 Vdc).

Then, disconnect the load supply lines from terminal blocks "15" - "16" and the output load from terminal blocks "13" - "14". Then, connect an ohmmeter (Ohm. A) between terminal blocks "15" - "13" and another one (Ohm. B) between terminal blocks "16" - "14". The **specific Proof test** consists of the following steps:

Steps	Action
1	Bypass the safety-related PLC or take other appropriate action to avoid a false trip when removing the unit for test.
2	<ol style="list-style-type: none"> 1. Do not supply the input channel (terminals "1"- "2") of the unit under test and verify that ohmmeters Ohm. A and Ohm. B measure absence of ohmic continuity (i.e. both +/AC and -/AC load lines are interrupted because the NO contacts are open: the 1st requisite is verified). For ohmmeter Ohm. A, this measure could also be verified if only one of two relay contacts in series is open and the other is blocked (for welding) in the closed or open position: this will be verified by testing the channel when the input is supplied, as described in point 3 of this procedure. On the other hand, the presence of ohmic continuity measured by ohmmeter Ohm. A implies that both relay contacts in series are blocked (for welding) in the closed position, while the presence of ohmic continuity measured by ohmmeter Ohm. B implies that the related relay contact is blocked (for welding) in the closed position. 2. Supply the input channel (terminals "1"- "2") of the unit under test and verify that ohmmeters Ohm. A and Ohm. B measure presence of ohmic continuity (i.e. both +/AC and -/AC load lines are not interrupted because all NO contacts are closed: the 2nd requisite is verified). The absence of ohmic continuity measured by ohmmeter Ohm. A implies that one of two relay contacts in series is blocked (for welding) in the open position: this could only be verified disassembling and individually testing each one of the two relay contacts. On the other hand, the absence of ohmic continuity measured by ohmmeter Ohm. B implies that the related relay contact is blocked (for welding) in the open position. 3. Always supply the input channel (terminals "1"- "2") of the unit under test and consider the measures of ohmmeter Ohm. A to verify if one of the two relay contacts in series is blocked (for welding) in the closed position; set ON the internal SW1 DIP-switches (n. 1 or 2) to put in short circuit one relay coil at a time (starting with the 1st coil by DIP-switch n. 1, then going on with the 2nd coil by DIP-switch n. 2), verifying that ohmic continuity is always absent between terminals "15" - "13". The presence of ohmic continuity implies that a relay contact (the only one with the de-energized coil because the related DIP-switch is set ON) is blocked (for welding) in the closed position.
3	Remove the bypass from the safety-related PLC or restore normal operation inserting the unit.

This test reveals almost 99 % of all possible Dangerous Undetected failures in the relay module.

Configuration

For configuration of T-proof relays testing, some DIP Switches are located on component side of pcb. These switches allow the T-proof relays test (SW1 dip-switch: 1-2-3 set "ON" and see "Testing procedure at T-proof" section for more information).

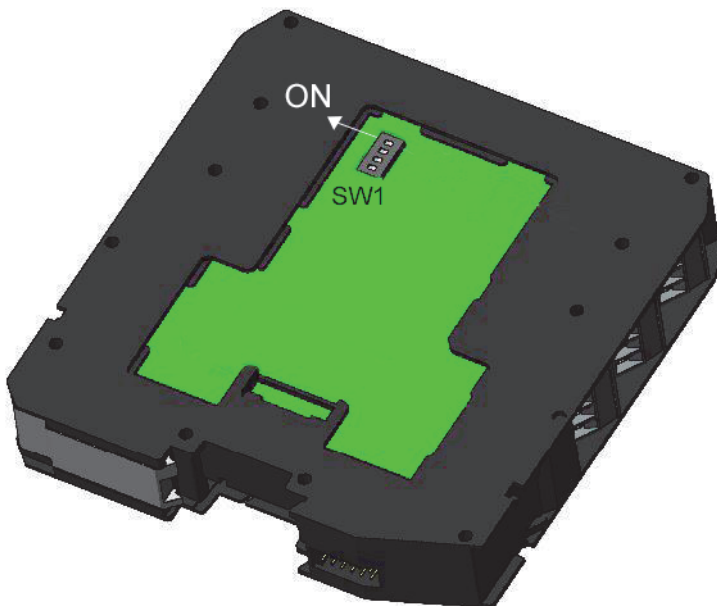

SW1 Dip switch configuration

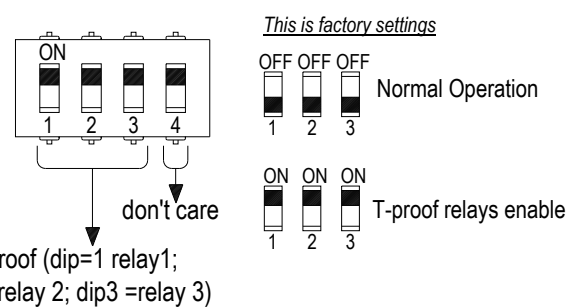

WARNING: after T-proof test, dip-switch 1-2-3 must be set to "OFF" position for normal operation.

Diagnostic Application for D5293S - SIL 2 Fault Relay Output with NO contact

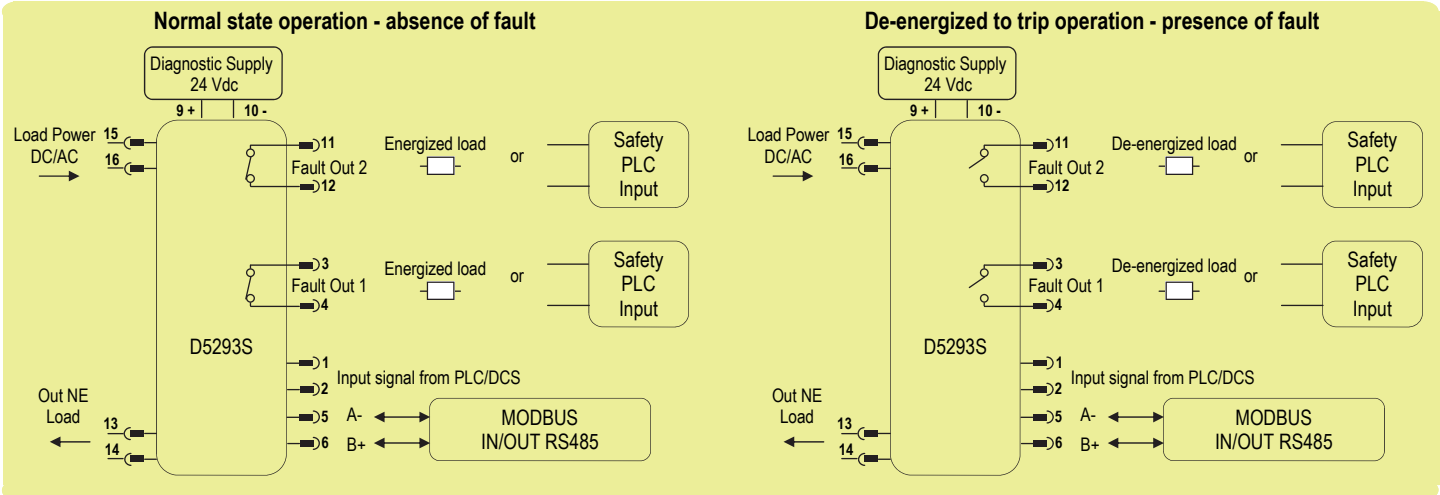

Description:

In this application D5293S module monitors Load Power DC/AC line (Pins 15-16) and Out NE Load (Pins 13-14) by internal diagnostic circuits and uses Fault Out 1 or Fault Out 2 NO contact to signal presence of faults on them. At pages 10-11 it's shown how to configure and to monitor the diagnostic operation parameters (as fault conditions), by means of Modbus IN/OUT protocol with RS485 connection (Pins 5-6) or by PPC5092 adapter and SWC5090 related software. When diagnostic supply is connected to Pins 9(+) - 10(-), the power green led is ON. NE load connected on Pins 13-14 is controlled by input signal Pins 1-2 from PLC/DCS. As shown in the diagram, Fault Output (Out 1 or Out 2) contact can be connected to Safety PLC Input or used to (de-)energize a load by switching its supply lines. Fault relay contact (Pins 3-4 for Fault Out 1 or 11-12 for Fault Out 2) is closed in normal state operation, that is absence of faults, energizing related load. This function is valid if "inverted fault relay" parameter is set to "0" or its field is not checked as explained at pages 10-11. In case of faults detected by internal diagnostic circuits, de-energized to trip operation is applied to fault relay and its contacts become open, de-energizing related load.

The following table describes the status (open or closed) of each fault output contact in absence or presence of faults detected by internal diagnostic circuits:

Operation	Fault Out 1 contact Pins 3-4	Fault Out 2 contact Pins 11-12
Normal (absence of fault)	Closed	Closed
Trip (presence of fault)	Open	Open

Safety Function and Failure behavior:

D5293S is considered to be operating in Low Demand mode, as a Type B module, having Hardware Fault Tolerance (HFT) = 0.

The failure behaviour of SPST fault relay output with NO contact and without "invert fault relay" condition by the following definitions:

- Fail-Safe State: it is defined as the diagnostic relay output being de-energized, with open contact and de-energizing related load;
- Fail Safe: this failure causes the system to go to the defined Fail-Safe state without a process demand;
- Fail Dangerous: failure mode that does not respond to a demand from the process (i.e. being unable to go to the defined Fail-Safe state), so that the diagnostic relay output remains energized or relay contact keeps closed (energizing related load) because of diagnostic measure error more than +/-20% of correct value or due to contact welding;
- Fail "No Effect": failure mode of a component that plays a part in implementing the safety function but that is neither a safe failure nor a dangerous failure; in particular, diagnostic measure error is less than +/-20% of correct value. When calculating the SFF, this failure mode is not taken into account;
- Fail "Not part": failure mode of a component which is not part of the Safety function but part of the circuit diagram and is listed for completeness. When calculating the SFF, this failure mode is not taken into account. The input and relay blocks failures are classified as "Not Part" failures.

As the module is supposed to be proven-in-use device, therefore according to the requirements of IEC 61511-1 section 11.4.4, a HFT = 0 is sufficient for SIL 2 (sub-) systems including Type B components and having a SFF equal or more than 60%.

Failure rate date: taken from Siemens Standard SN29500.

Failure rate table:

Failure category	Failure rates (FIT)
λ_{dd} = Total Dangerous Detected failures	0.00
λ_{du} = Total Dangerous Undetected failures	97.12
λ_{sd} = Total Safe Detected failures	0.00
λ_{su} = Total Safe Undetected failures	216.93
$\lambda_{tot\ safe}$ = Total Failure Rate (Safety Function) = $\lambda_{dd} + \lambda_{du} + \lambda_{sd} + \lambda_{su}$	314.05
MTBF (safety function, single channel) = $(1 / \lambda_{tot\ safe}) + MTTR$ (8 hours)	363 years
$\lambda_{no\ effect}$ = "No effect" failures	117.75
$\lambda_{not\ part}$ = "Not Part" failures	436.70
$\lambda_{tot\ device}$ = Total Failure Rate (Device) = $\lambda_{tot\ safe} + \lambda_{no\ effect} + \lambda_{not\ part}$	868.50
MTBF (device, single channel) = $(1 / \lambda_{tot\ device}) + MTTR$ (8 hours)	131 years

Failure rates table according to IEC 61508:

λ_{sd}	λ_{su}	λ_{dd}	λ_{du}	SFF
0.00 FIT	216.93 FIT	0.00 FIT	97.12 FIT	69.07%

This type "B" system has SFF = 69.07% \geq 60% and HFT = 0, which is sufficient to get SIL 2 in accordance with the requirements of IEC 61511-1 section 11.4.4 during a proven-in-use assessment.

PFDavg vs T[Proof] table (assuming Proof Test coverage of 99%), with determination of SIL supposing module contributes 10% of entire safety function:

T[Proof] = 1 year	T[Proof] = 2 years	T[Proof] = 20 years
PFDavg = 4.26 E-04 - Valid for SIL 2	PFDavg = 8.52 E-04 - Valid for SIL 2	PFDavg = 8.52 E-03 - Valid for SIL 1

PFDavg vs T[Proof] table (assuming Proof Test coverage of 99%), with determination of SIL supposing module contributes 20% of entire safety function:

T[Proof] = 4 years	T[Proof] = 20 years
PFDavg = 1.70 E-03 - Valid for SIL 2	PFDavg = 8.52 E-03 - Valid for SIL 1

Diagnostic Application for D5293S - SIL 2 for Modbus Output with RS485 connection

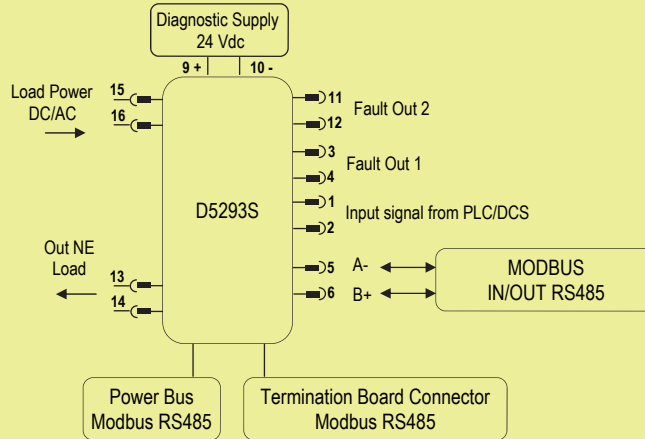

Description:

In this application D5293S module monitors Load Power DC/AC line (Pins 15-16) and Out NE Load (Pins 13-14) by internal diagnostic circuits and uses Modbus protocol with RS485 connection to signal presence of faults on them. At pages 10-11 it's shown how to configure and to monitor the diagnostic operation parameters (as fault conditions), by means of Modbus IN/OUT protocol with RS485 connection (Pins 5-6) or by PPC5092 adapter and SWC5090 related software. When diagnostic supply is connected to Pins 9(+)- 10(-), the power green led is ON. NE load connected on Pins 13-14 is controlled by input signal Pins 1-2 from PLC/DCS. As shown in the diagram, Modbus RS485 is available on Pins 5-6 or on Power Bus connector or on Termination Boards connector. At pages 10-11 it's described how modbus parameters change their status when internal diagnostic circuits detect presence of faults on Load Power DC/AC line or Out NE Load.

Safety Function and Failure behavior:

D5293S is considered to be operating in Low Demand mode, as a Type B module, having Hardware Fault Tolerance (HFT) = 0.

The failure behaviour is described by the following definitions:

- Fail-Safe State: it is defined as the ModBus communication being shut down OR any analog measure value (expressed in ModBus parameters) going to Fail High or Fail Low;
- Fail Safe: this failure causes the system to go to the defined Fail-Safe state without a process demand;
- Fail Dangerous: failure mode that does not respond to a demand from the process (i.e. being unable to go to the defined Fail-Safe state), so that any analog measure expressed in ModBus parameters) is deviated by more than ± 20% of the correct value;
- Fail High: it is defined as a failure that causes any analog measure (expressed in ModBus parameters) to go above its maximum allowed value (which can be set by the user);
- Fail Low: it is defined as a failure that causes any analog measure (expressed in ModBus parameters) to go below its minimum allowed value (which can be set by the user);
- Fail "No Effect": failure mode of a component that plays a part in implementing the safety function but that is neither a safe failure nor a dangerous failure; in particular, analog measure (expressed in ModBus parameters) is deviated by less than ± 20% of the correct value. When calculating the SFF, this failure mode is not taken into account;
- Fail "Not part": failure mode of a component which is not part of the Safety function but part of the circuit diagram and is listed for completeness. When calculating the SFF, this failure mode is not taken into account. The input and relay blocks failures are classified as "Not Part" failures.

Assuming that the application program in the safety logic solver is configured to detect under-range (Low) and over-range (High) failures and does not automatically trip on these failures, these failures have been classified as dangerous detected (DD) failures.

As the module is supposed to be proven-in-use device, therefore according to the requirements of IEC 61511-1 section 11.4.4, a HFT = 0 is sufficient for SIL 2 (sub-) systems including Type B components and having a SFF equal or more than 60%.

Failure rate date: taken from Siemens Standard SN29500.

Failure rate table:

Failure category	Failure rates (FIT)
λ_{dd} = Total Dangerous Detected failures	42.42
λ_{du} = Total Dangerous Undetected failures	51.10
λ_{sd} = Total Safe Detected failures	0.00
λ_{su} = Total Safe Undetected failures	101.83
$\lambda_{tot\ safe}$ = Total Failure Rate (Safety Function) = $\lambda_{dd} + \lambda_{du} + \lambda_{sd} + \lambda_{su}$	195.35
MTBF (safety function, single channel) = $(1 / \lambda_{tot\ safe}) + MTTR$ (8 hours)	584 years
$\lambda_{no\ effect}$ = "No effect" failures	114.65
$\lambda_{not\ part}$ = "Not Part" failures	558.50
$\lambda_{tot\ device}$ = Total Failure Rate (Device) = $\lambda_{tot\ safe} + \lambda_{no\ effect} + \lambda_{not\ part}$	868.50
MTBF (device, single channel) = $(1 / \lambda_{tot\ device}) + MTTR$ (8 hours)	131 years

Failure rates table according to IEC 61508:

λ_{sd}	λ_{su}	λ_{dd}	λ_{du}	SFF
0.00 FIT	101.83 FIT	42.42 FIT	51.10 FIT	73.84%

This type "B" system has SFF = 73.84% ≥ 60% and HFT = 0, which is sufficient to get SIL 2 in accordance with the requirements of IEC 61511-1 section 11.4.4 during a proven-in-use assessment.

PFDavg vs T[Proof] table (assuming Proof Test coverage of 99%), with determination of SIL supposing module contributes 10% of entire safety function:

T[Proof] = 1 year	T[Proof] = 4 years	T[Proof] = 20 years
PFDavg = 2.25 E-04 - Valid for SIL 2	PFDavg = 8.98 E-04 - Valid for SIL 2	PFDavg = 4.49 E-03 - Valid for SIL 1

PFDavg vs T[Proof] table (assuming Proof Test coverage of 99%), with determination of SIL supposing module contributes 20% of entire safety function:

T[Proof] = 8 years	T[Proof] = 20 years
PFDavg = 1.80 E-03 - Valid for SIL 2	PFDavg = 4.49 E-03 - Valid for SIL 1

Testing procedure at T-proof for diagnostic application

According to IEC 61508-2, the proof test will be performed to reveal dangerous faults which cannot be otherwise detected. This means that it is necessary to specify how dangerous undetected faults, which have been noted during the FMEDA analysis, can be revealed during the proof test.

When the diagnostic circuits of D5293S are used with the 1 +1 SPST fault relay output, the **Proof Test** consists of the following steps:

Steps	Action
1	Bypass the Safety PLC or take any other appropriate action to avoid a false trip.
2	By means of the configuration software, configure each fault relay output to be energized with closed contacts in normal operation and de-energized with open contacts when a fault condition occurs. Connect an ohmmeter to each couple of relay contacts and verify that, during the modules normal operation, the fault relay outputs are energized with presence of ohmic continuity between their contacts.
3	Impose a fault condition to any of the analog measures performed by the modules (for example, if coil integrity is enabled, by means of the SW1 dip-switch, it is possible to short circuit any of the output relay coils). Verify that, during fault condition, the fault relay outputs are de-energized with absence of ohmic continuity between their contacts. Finally, remove the fault condition (for example, remove the output relay coil short circuit by means of the SW1 dip-switch) and verify that the fault relay outputs are switched to the energized state with presence of ohmic continuity between their contacts.
4	Connect the modules to the RS485 ModBus interface and use the configuration software to read the values of the analog measures performed by the modules. Impose different line and load conditions by means of AC or DC voltage generator and passive or active load and verify that the values detected by means of the configuration software are within +/- 20% of the imposed values. Perform this test when the modules output relays are both in the energized and de-energized states.
5	Shut down ModBus communication and verify that the configuration software indicates a communication error. Finally, restore ModBus communication and verify that the configuration software still indicates the values of the performed analog measures with a tolerance lower than +/- 20%.
6	Restore the loop to full operation
7	Remove the bypass from the Safety-related PLC or restore normal operation.

This test will reveal approximately 99% of the possible Dangerous Undetected failures in the diagnostic circuits of D5293S when the fault relay output is considered.

When the diagnostic circuits of D5293S are used with the ModBus output with RS485 connection, the **Proof Test** consists of the following steps:

Steps	Action
1	Bypass the Safety PLC or take any other appropriate action to avoid a false trip.
2	Connect the modules to the RS485 ModBus interface and use the configuration software to read the values of the analog measures performed by the modules. Impose different line and load conditions by means of AC or DC voltage generator and passive or active load and verify that the values detected by means of the configuration software are within +/- 20% of the imposed values. Perform this test when the modules output relays are both in the energized and de-energized states.
3	Shut down ModBus communication and verify that the configuration software indicates a communication error. Finally, restore ModBus communication and verify that the configuration software still indicates the values of the performed analog measures with a tolerance lower than +/- 20%.
4	Restore the loop to full operation
5	Remove the bypass from the Safety-related PLC or restore normal operation.

This test will reveal approximately 99% of the possible Dangerous Undetected failures in the diagnostic circuits of D5293S when the ModBus output is considered.

Warning

D5293S is an electrical apparatus installed into standard EN50022 T35 DIN-Rail located in Safe Area or Zone 2, Group IIC, Temperature Classification T4, Hazardous Area (according to EN/IEC60079-15) within the specified operating temperature limits Tamb - 40 to +60 °C. D5293S must be installed, operated and maintained only by qualified personnel, in accordance to the relevant national/international installation standards (e.g. IEC/EN60079-14 Electrical apparatus for explosive gas atmospheres - Part 14: Electrical installations in hazardous areas (other than mines)), following the established installation rules. De-energize power source (turn off power supply voltage) before plug or unplug the terminal blocks when installed in Hazardous Area or unless area is known to be nonhazardous. **Warning: substitution of components may impair suitability for Zone 2. Warning: de-energize main power source (turn off power supply voltage) and disconnect plug-in terminal blocks before opening the enclosure to avoid electrical shock when connected to live hazardous potential. Explosion Hazard: to prevent ignition of flammable or combustible atmospheres, disconnect power before servicing or unless area is known to be nonhazardous.** Failure to properly installation or use of the equipment may risk to damage the unit or severe personal injury. The unit cannot be repaired by the end user and must be returned to the manufacturer or his authorized representative. Any unauthorized modification must be avoided.

Operation

The single channel 5 A Relay Output D5293S is a relay module suitable for the switching of safety related circuits, up to SIL 3 level according to IEC 61508:2010 Ed. 2 for high risk industries. It provides isolation between input and output contacts. D5293S has 1+1 SPST contact for normally energized load. SIL 3 Safety Function for NE load (de-energized in fail safe state) is available at Terminal Blocks 13-14. When the driving signal is high (24 Vdc), the relay is energized (normal state), SIL 3 contacts at terminals 13-15 and 14-16 are closed, the load is energized. The safety function is met when the driving signal is low (0 Vdc), the relay is de-energized (fail safe state), SIL 3 contacts at terminals 13-15 and 14-16 are opened, the load is de-energized. Presence of diagnostic circuit power supply, status of input / output channel (energized or de-energized), as well as any type of fault condition (line and load short/open circuit, relay coil short circuit, etc.) are displayed by related signalling LEDs: green power supply, yellow for status channel and red for fault.

Installation

D5293S is a relay output module housed in a plastic enclosure suitable for installation on T35 DIN-Rail according to EN50022, with or without Power Bus or on customized Termination Board. D5293S unit can be mounted with any orientation over the entire ambient temperature range. Electrical connection of conductors up to 2.5 mm² are accommodated by polarized plug-in removable screw terminal blocks which can be plugged in/out into a powered unit without suffering or causing any damage (**for Zone 2 installations check the area to be nonhazardous before servicing**). The wiring cables have to be proportionate in base to the current and the length of the cable.

On the section "Function Diagram" and enclosure side a block diagram identifies all connections.

Identify the function and location of each connection terminal using the wiring diagram on the corresponding section, as an example:

Connect 24 Vdc power supply positive at terminal "9" and negative at terminal "10".

Connect positive input at terminal "1" and negative input at "2".

Connect Fault output 1 (30 V, 500mA) at terminals "3" and "4" and Fault output 2 (250 V, 3A) at terminals "11" and "12".

Connect A- Modbus RS485 for diagnostic at terminal "5" and B+ at terminal "6".

Connect positive output Normally Energized load at terminal "13" and negative at terminal "14".

Connect positive Load Power DC/AC at terminal "15" and negative at terminal "16".

Installation and wiring must be in accordance to the relevant national or international installation standards (e.g. IEC/EN60079-14 Electrical apparatus for explosive gas atmospheres Part 14: Electrical installations in hazardous areas (other than mines)), make sure that conductors are well isolated from each other and do not produce any unintentional connection.

Connect 1+1 SPST relay contacts checking the load rating to be within the contact maximum rating 5 A 250 Vac 1250 VA, 5 A 250 Vdc 140 W (resistive load). **To prevent relay contacts from damaging, connect an external protection (fuse or similar), chosen according to the relay breaking capacity diagram on data sheet.** The enclosure provides, according to EN60529, an IP20 minimum degree of mechanical protection (or similar to NEMA Standard 250 type 1) for indoor installation, outdoor installation requires an additional enclosure with higher degree of protection (i.e. IP54 to IP65 or NEMA type 12-13) consistent with the effective operating environment of the specific installation. Units must be protected against dirt, dust, extreme mechanical (e.g. vibration, impact and shock) and thermal stress, and casual contacts. If enclosure needs to be cleaned use only a cloth lightly moistened by a mixture of detergent in water. **Electrostatic Hazard: to avoid electrostatic hazard, the enclosure of D5293S must be cleaned only with a damp or antistatic cloth.** Any penetration of cleaning liquid must be avoided to prevent damage to the unit. Any unauthorized card modification must be avoided. According to EN61010, D5293 must be connected to SELV or SELV-E supplies. Relay output contact must be connected to load non exceeding category II overvoltage limits. **Warning: de-energize main power source (turn off power supply voltage) and disconnect plug-in terminal blocks before opening the enclosure to avoid electrical shock when connected to live hazardous potential.**

Start-up

Before powering the unit check that all wires are properly connected, particularly supply conductors and their polarity, input and output wires. Check conductors for exposed wires that could touch each other causing dangerous unwanted shorts. Turn on power for diagnostic circuit, the "power on" green led must be lit. Enabling input, the channel status yellow led must be lit and load circuit must be energized because 1+1 SPST relay output contacts are closed. Instead, disabling input, the channel status yellow led must be turned off and load circuit must be de-energized because 1+1 SPST relay output contacts are open.

PPC5092 Adapter - Operation

The Pocket Portable Adapter type PPC5092 is suitable to connect the module D5293S to a PC via USB serial line, in order to configure and to monitor the operation parameters by means of SWC5090 software. The PPC5092 unit is connected to D5293S by mini USB and to PC by USB port. This adapter is not ATEX, UL or FM approved and is only to be used in Safe Area/Non Hazardous Locations. Do not use PPC5092 in Hazardous Area/Hazardous Locations. The PPC5092 adapter is powered by the PC (no battery power) when its USB port is plugged into the PC. It has a green LED as power-on indication.

SWC5090 Configuration & Monitoring Software

Configuration parameters:

USER MANUAL SETTINGS:

Load Supply Voltage RMS

- Voltage Upper Limit (V): Maximum allowed load RMS voltage
- Voltage Lower Limit (V): Minimum allowed load RMS voltage

Load Current RMS

- Current Upper Limit (A): Maximum allowed load RMS current
- Current Lower Limit (A): Minimum allowed load RMS current

FAULT CONDITIONS MONITORING (Command Status [ON]): Faults contributing to the output cumulative fault when the driver is on.

FAULT CONDITIONS MONITORING (Command Status [OFF]): Faults contributing to the output cumulative fault when the driver is off.

- Load Supply Voltage: When checked, the load supply voltage can activate the cumulative fault.
- Load Current: When checked, the load current can activate the cumulative fault.

TAG: Identification of the specific operating loop of the module.

ACQUIRE FUNCTIONS: Acquisition and saving of the diagnostics field parameters.

- Acquire OFF parameters: The currently measured OFF parameters are copied to the USER MANUAL SETTINGS (available only when the driver is OFF).
- Acquire ON parameters: The currently measured ON parameters are copied to the USER MANUAL SETTINGS (available only when the driver is ON).

CONTINUOUS SCAN: Continuous measurement of the field parameters.

- Start/Stop: Activates/de-activates the measurement of the field parameters.

INVERT FAULT RELAY: When not checked, the output fault contacts open in case of fault. When checked, the output fault contacts close in case of fault.

For [SIL application](#), this field must not be checked.

Note: For advanced options and details on SWC5090, please refer to ISM0154.

Screenshots:

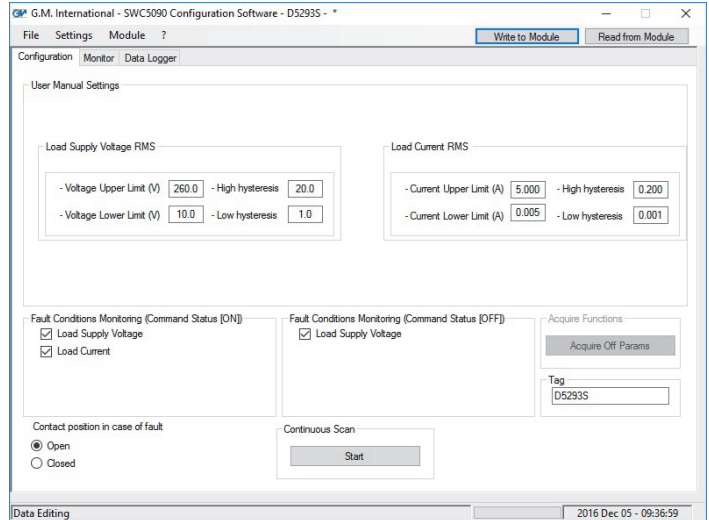

Configuration

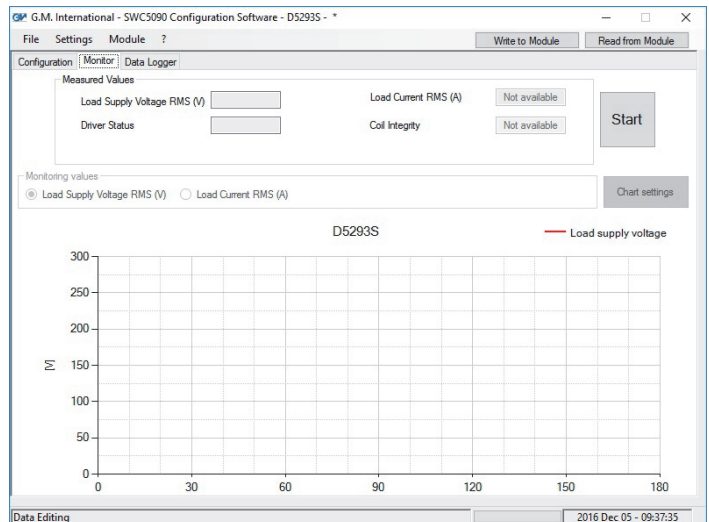

Monitor

Supported ModBus Parameters:

D5293S communicates via Modbus RTU-485 protocol. Below are all available registers.

Param. Address	Description	Notes	Type ⁽¹⁰⁾
0	G.M. Factory Code	Identification Data	R
1	Instrument Code		
2	Option Code		
3	Hardware Release		
4	Software Release		
16	Modbus Address	Communication Data	R/W
17	Modbus Baudrate ⁽¹⁾		
18	Modbus Format ⁽¹⁾		
64	Measured Load Voltage ⁽²⁾	Input Data	R
65	Measured Load Current ⁽³⁾		
69	Driver Status ⁽⁴⁾		
72	Masked Fault Status ⁽¹⁾		
101	Load Voltage Upper Limit ⁽²⁾	Input Configuration	R/W
102	Load Voltage Lower Limit ⁽²⁾		
103	Load Current Upper Limit ⁽³⁾		
104	Load Current Lower Limit ⁽³⁾		
112	Fault Mirror Configuration ⁽⁵⁾		
113	Invert Fault Relay ⁽⁶⁾		
114	Load Voltage Upper Hysteresis ⁽²⁾		
115	Load Voltage Lower Hysteresis ⁽²⁾		
116	Load Current Upper Hysteresis ⁽³⁾	Alarm Control	R/W
117	Load Current Lower Hysteresis ⁽³⁾		
224	Fault Mask (Driver ON)	Alarm Control	R/W
225	Fault Mask (Driver OFF)		
464	Command execution ⁽⁷⁾	Command	W
548 to 555	Tag ⁽⁸⁾	Tags	R/W

Parameters Details:

Address 17: Supported ModBus Baudrates

Index	Baudrate
0	4800
1	9600
2	19200
3	38400
4	57600
5	115200

Address 18: Supported Modbus Formats

High Byte								Low Byte							
Bit position															
15	14	13	12	11	10	9	8	7	6	5	4	3	2	1	0

Endianness 32 bit Data (0 = Little; 1 = Big) ———→

Termination resistance (1 = enabled) ———→

Supported Modbus Parity:
 0 8 data bit, no parity, 1 stop bit
 1 8 data bit, even parity, 1 stop bit
 2 8 data bit, odd parity, 1 stop bit

Address 72: Fault status

High Byte								Low Byte							
Bit position															
15	14	13	12	11	10	9	8	7	6	5	4	3	2	1	0

Don't care bit ———→

Coil Integrity ———→

Load Current ———→

Load Voltage ———→

0= Ok
1= Fault

Addresses 224-225: Fault conditions

High Byte								Low Byte							
Bit position															
15	14	13	12	11	10	9	8	7	6	5	4	3	2	1	0

Don't care bit ———→

Coil Integrity ———→

Load Current ———→

Load Voltage ———→

0= Ok
1= Fault

Address 464: Commands

High Byte								Low Byte							
Bit position															
15	14	13	12	11	10	9	8	7	6	5	4	3	2	1	0

1 Save Input/Output Configuration
 2 Save Modbus Configuration
 8 Save Tags

Configuration Parameters:

Each Modbus parameter is described by one 16-bit word.

- (1) See command details on the right.
- (2) Expressed in 100 mV
- (3) Expressed in mA
- (4) 0= OFF; 1= ON
- (5) 0= Fault mirror; 1= Always OFF; 2= Always ON
- (6) 0= no inversion (open: fault, for SIL application); 1= inverted (open: ok)
- (7) All configurations must be confirmed via Addr. 464, see details on the right.
- (8) Tags are composed of 16 characters.
Each address contains 2 chars, starting from left.
- (9) Parameter Type:
 R= read only
 W= write only
 R/W= read and write

Code	Name	Notes
03	read holding registers	reads a stream of words from memory
04	read input registers	reads a stream of words from memory
08	diagnostics: subcode 0	returns query data
06	write single registers	writes a word in memory
16	write multiple registers	writes a stream of words in memory